

PN 10/16/25 Atm
DN 50/600 mm

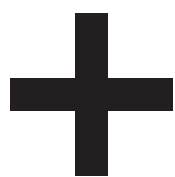

Hydraulic Valves

HYDROMAF

100

Float control valve - modulating

It maintains full tank, opening the valve as the level drops.



mafusa

Avda dels Transports, Sector 13
Parcela 45A, 46394, Ribarroja del Turia
Valencia, España

Phone: 96 166 70 35
Fax: 96 166 90 89

www.mafusa.net
mafusa@mafusa.net

+ Dimensions

Main Valve - Fully Bore Type

DN	L	H	H1*	K	S	Peso (Kg)
40S-1 1/2"	230	139	55	173	3/8"	13
50S-2"	230	139	55	173	3/8"	13
50	230	139	85	173	3/8"	14
65	290	159	95	198	3/8"	19
80	310	179	102	226	3/8"	23
100	350	214	112	265	3/8"	32
150	480	333	145	351	1/2"	68
200	600	407	72	436	3/4"	125
250	730	476	205	524	1"	200
300	850	526	232	606	1"	260
400	1100	624	292	741	1 1/2"	560
500	1250	720	360	1002	2"	880
600	1450	835	425	1308	2"	1300
800	1850	1110	515	1755	2"	1950
1000	2250	1350	630	2231	2"	2456

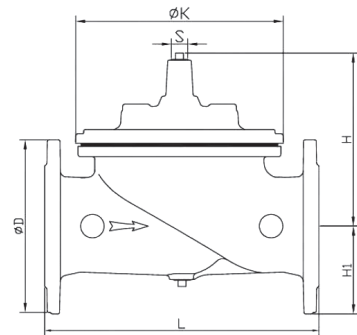
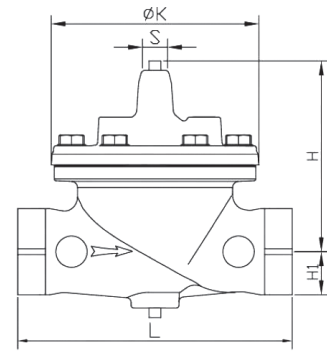

Main Valve - Reduced Bore Type

DN	L	H	H1*	K	S	Peso (Kg)
65	230	139	95	173	3/8"	21
80	290	159	102	198	3/8"	28
100	350	179	112	226	3/8"	39
125	350	214	127	265	3/8"	56
150	480	214	145	265	3/8"	96
200	600	333	172	351	1/2"	162
250	730	407	205	436	3/4"	230
300	850	476	232	524	1"	285
350	850	526	262	606	1"	435
400	1100	526	292	606	1"	590
450	1100	624	325	741	1 1/2"	750
500	1100	624	360	741	1 1/2"	1090
600	1250	720	425	1002	2"	1200
700	1450	835	460	1308	2"	1420
800	1450	835	515	1308	2"	1510
900	1850	1110	570	1755	2"	2185
1000	1850	1110	630	1755	2"	2268
1200	2250	1350	750	2231	2"	2855

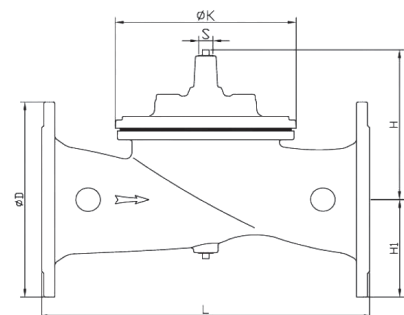



Head losses

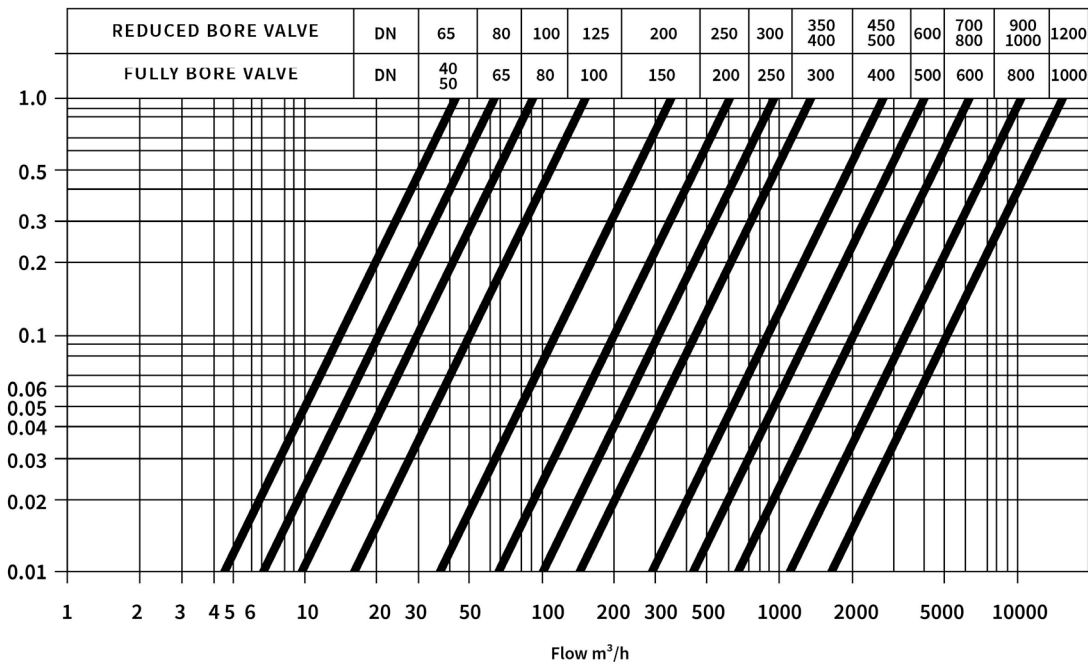

Cavitation guide chart

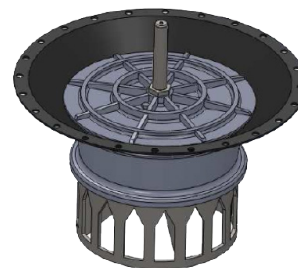
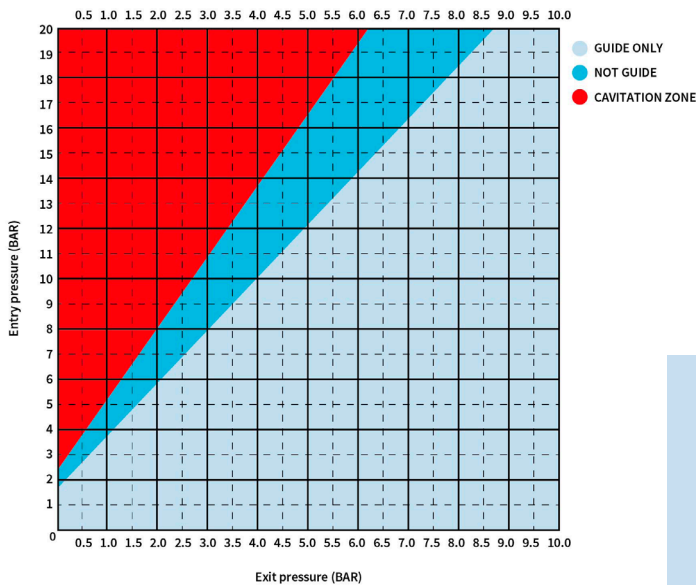

Anti-cavitation Kit

The anti-cavitation mold has been designed for applications where there is a high damage potential for damage from cavitation, providing an optimum internal pressure control through a unique anti-cavitation trim design and relieving the damage of cavitation with multi-stage pressure reducing.



Standards and specifications

USE	STANDARD	CONNEXION
Use: Water Temp: -41° - 220 °C	Standard Designs EN 1074-5 BS EN 1567	Face to face EN 558-1 / ISO 5752 Serie 1
Pressure Range: ISO EN PN10, PN16, PN25 ANSI CL125/150/300 JIS 10K/16K AS Table D, E	Standard Test ISO 5208 / EN 12266-1	Flange Drilling EN 1092-2 ISO 7005-2



Product description

Basic valve, floating pilot 2W stainless steel, stainless steel needle valve and ball valve from DN250. Precise throttle and restriction holes.



Operation

The model 100 level control valve is a modulating valve that accurately controls the liquid level in tanks. This valve is designed to open when the liquid level reaches a preset low point, and close drip-tight when the level reaches a preset high point. The float pilot is remotely installed inside of reservoir. This is a hydraulically operated, diaphragm valve with the pilot control and float mechanism mounted on the cover of the main valve.



Setting

- 1° Open the needle valve at least 3 turns and open the floodgates to allow passage of water.
- 2° Close the ball valve located in the tube of the float pilot to simulate the closure per buoy. Check the closing time.
- 3° Open the ball valve and check valve is working properly.
- 4° Close the valve by the buoy and check the closing time.
- 5° Regulate the needle valve if was necessary. Open a little in case of excessive closing time or close in case of sudden closure or if we observe that the valve remains in semi-closed position during filling.

Note.- If want to close the valve manually we can do it by closing the ball valve located on the drive tube of the pilot.

+ Control diagram

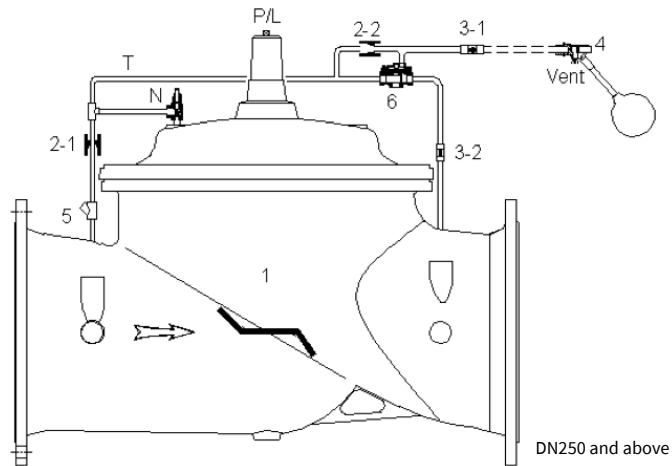
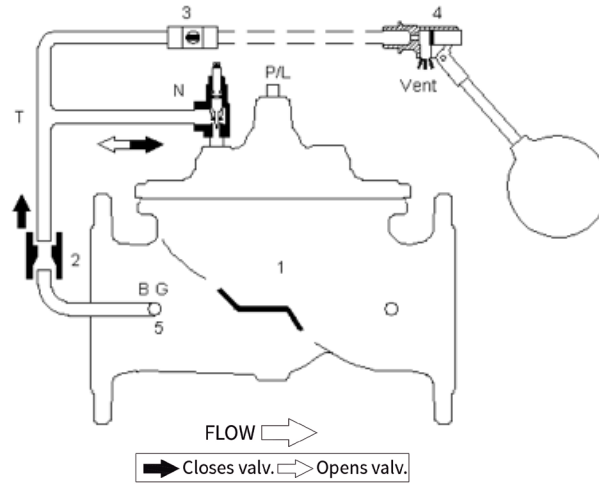

+ Standard configuration

- 1. Main valve
- 2. Restriction
- 3. Ball valve
- 4. Float pilot
- 5. Strainer
- 6. *Accelerator(DN250 & above)

+ Optional configuration

- N. Needle valve
- B. Ball valve
- G. Pressure Gauge
- P. Position indicator
- L. Limit switch

+ Typical installation

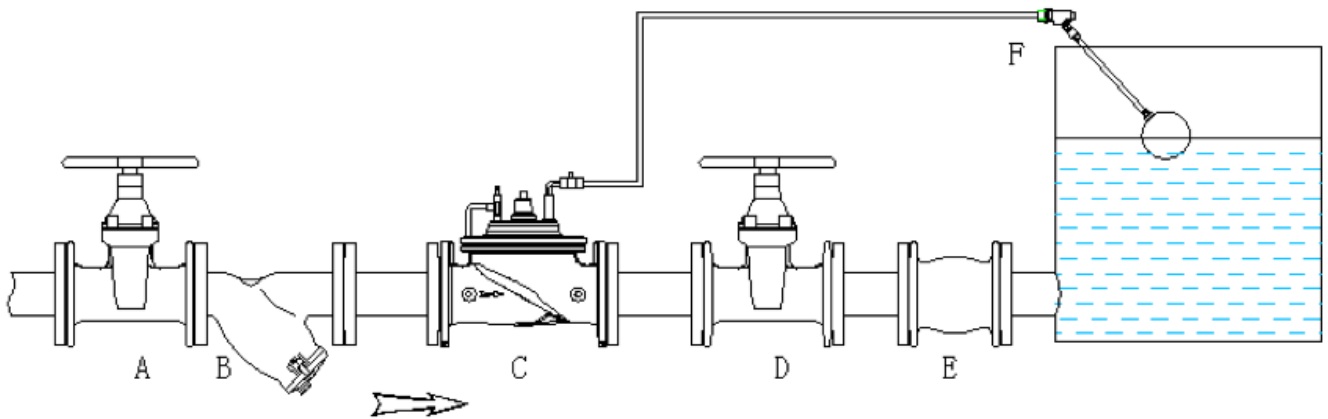

For carrying out the setting and maintenance of hydraulic valve, it is essential the installation of the following items:

1. Shutoff valves before and after hydraulic, as shown in the graph. With them we can also simulate various flow conditions for regulation and attend the slow filling of the pipe.
2. The cast iron Y strainer prevents the penetration of any element in the hydraulic valve that difficult it's proper functioning. Much of the anomalies are given by the absence of this element.
3. It should be used some antiwave system to ensure the absence of oscillations in the pilot used.

It's very important to check that the diameter of the valve is adjusted to the ranges of actual flows and never oversizing the valve.

Material list

- A. Inlet isolation valve
- B. Strainer
- C. Float valve
- D. Outlet isolation valve
- E. Flexible connector
- F. Remote float pilot

Excluded from the guarantee all those valves are not installed in accordance with these recommendations.