

Generic data

Nominal pressure		1,0	1,6	MPa
Test pressure	Body	1,5	2,4	
	Seat test	1,1	1,76	
Medium temperature		0-80°		°C
Applicable media		Water / oils etc.		

Properties

- **Design code:** BS EN 593
- **End flange:** BS EN 1092-2
- **Pressure ratio:** PN 10/16
- **Face to face:** BS EN 558 1 Series 14
- **Body:** Ductile iron GGG50, epoxy coating
- **Test standards:** BS EN 12266-1

Materials

N°	NAME	MATERIAL	STANDARD
1	Gearbox	Stainless Steel	EN10088-3
2	X Ring	NBR	EN 681-1
3	Sealing sleeve	Cu59-1	DIN17664
4	Spindle	20Cr13	EN10088-3
5	Body	Ductile Iron	EN1691
6	Disc	Ductile Iron	EN1691
7	Bearing	SF15	
8	Split snap ring	ZCuZn25Al6Fe6Mn6	DIN17664
9	Sealing ring plate	Stainless Steel	EN10088-3
10	Disc seal ring	EPDM	EN 681-1

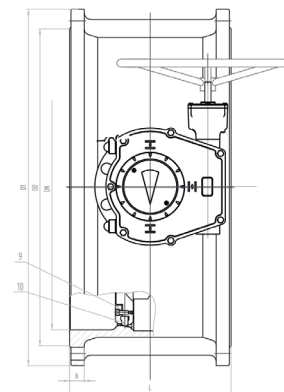

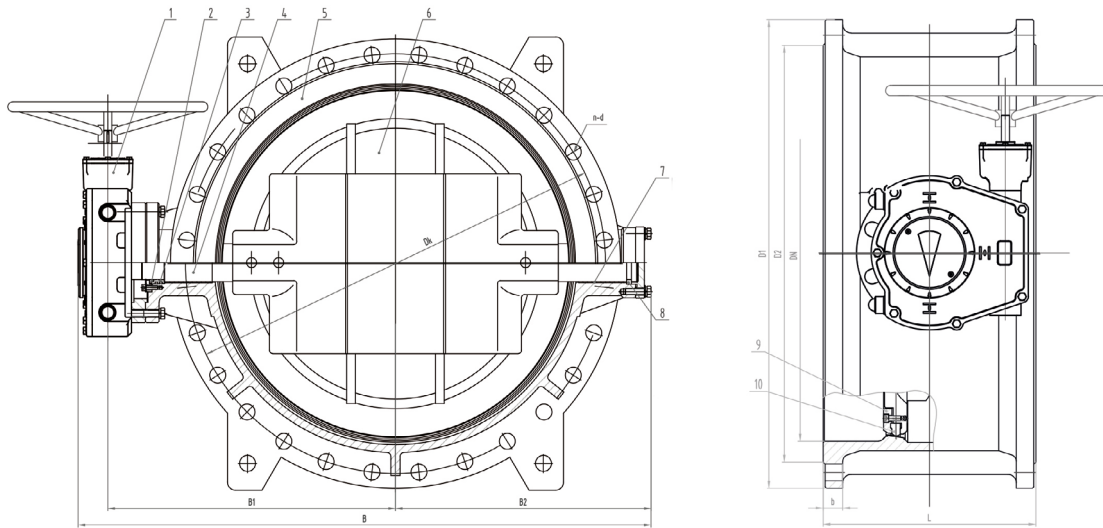

Dimensions

DN	PN10				PN16				L	B1	B2	B	Weight (kg)
	D1	Dk	n-ød	b	D1	Dk	n-ød	b					
200	340	295	8-23	20	340	295	12-23	20	230	314	174	524	56
250	395	350	12-23	22	405	355	12-28	22	250	354	200	603	64
300	445	400	12-23	24,5	460	410	12-28	24,5	270	388	258	695	85
350	505	460	16-23	24,5	520	470	16-28	26,5	290	446	292	790	125
400	565	515	16-28	24,5	580	525	16-31	28	310	522	331	910	165
450	615	565	20-28	25,5	640	585	20-31	30	330	535	365	953	205
500	670	620	20-28	26,5	715	650	20-34	31,5	350	566	405	1028	265
600	780	725	20-31	30	840	770	20-37	36	390	662	468	1195	405
700	895	840	24-31	32,5	910	840	24-37	39,5	430	627	520	1212	500
800	1015	950	24-34	35	1025	950	24-40	43	470	680	583	1338	680
900	1115	1050	28-34	37,5	1125	1050	28-40	46,5	510	725	635	1435	880
1000	1230	1160	28-37	40	1255	1170	28-43	50	550	826	695	1620	1160
1200	1455	1380	32-40	45	1485	1390	32-49	57	630	972	820	1910	1780
1400	1675	1590	36-43	46	1685	1590	36-49	60	710	1140	928	2140	2670
1600	1915	1820	40-49	49	1930	1820	40-56	65	790	1270	1050	2410	3850
1800	2115	2020	44-49	52	2130	2020	44-56	70	870	1410	1175	2680	5350
2000	2325	2230	48-49	55	2345	2230	48-62	75	950	1620	1315	3135	6955
2200	2550	2440	52-56	60	2555	2440	52-62	80	1000	1800	1465	3465	9040
2400	2760	2650	56-56	65	2765	2650	56-62	85	1100	1990	1620	3810	11750